

Measuring electronic sensor of d.c., a.c., pulsating currents with a galvanic insulation between primary and secondary circuits.
Capteur électronique de mesure de courants d.c., a.c., impulsions, avec isolation galvanique entre circuits primaire et secondaire.

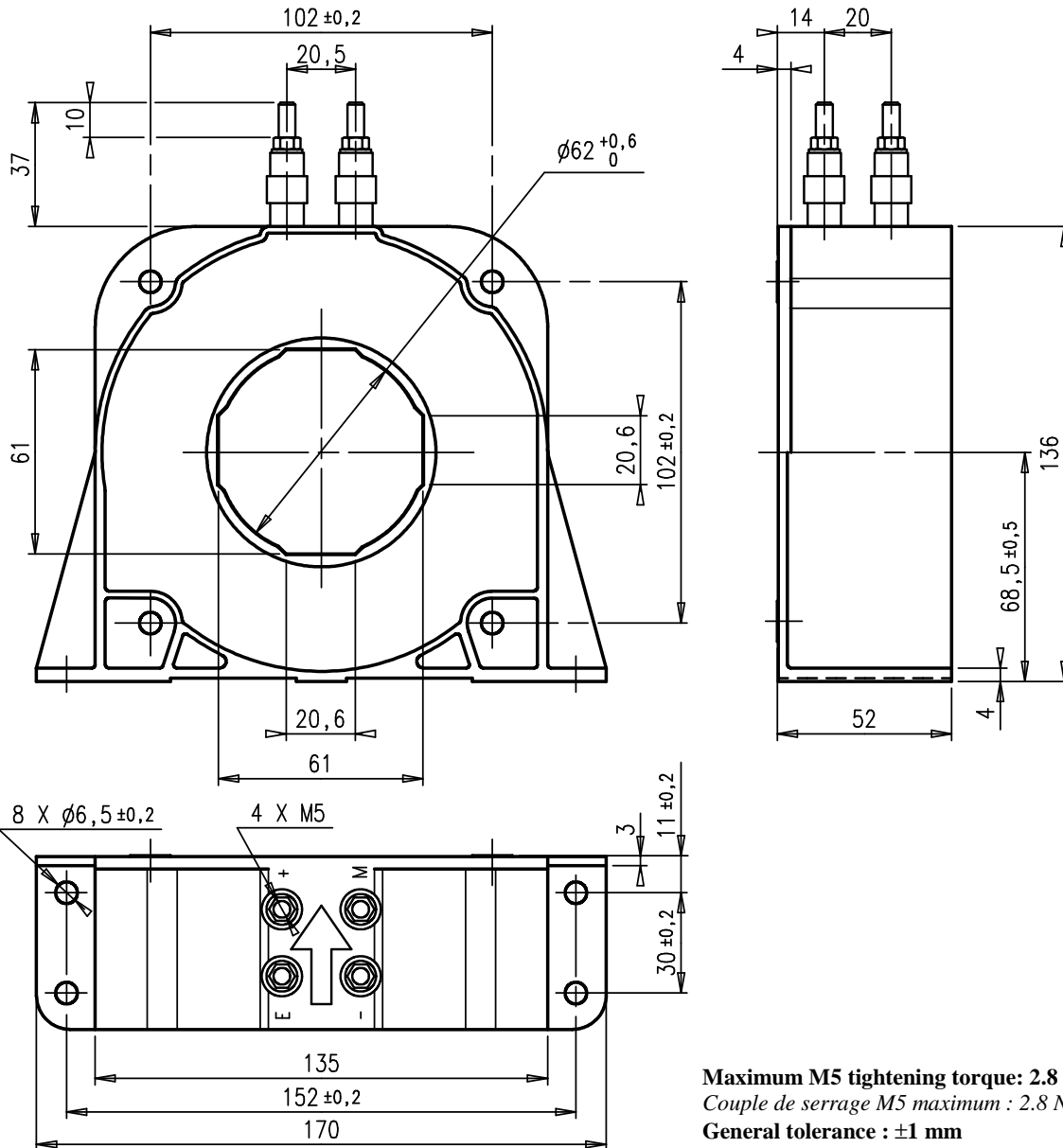

Maximum M5 tightening torque: 2.8 N.m
Couple de serrage M5 maximum : 2.8 N.m
General tolerance : ± 1 mm
Tolérance générale : ± 1 mm

GENERAL DESCRIPTION

Coated electronic circuit
Self extinguishing plastic case
Direction of the secondary current: A primary current flowing in the direction of the arrow results in a positive output current from M terminal.

- Protections :**
- Of the measuring circuit against short-circuits
 - Of the measuring circuit against opening
 - Of the power supply against polarity reversal

Instructions for use and mounting according to our catalogue

DESCRIPTION GENERALE

Circuit électronique enrobé
Boîtier en matière isolante auto-extinguible
Sens du courant secondaire : Un courant primaire circulant dans le sens de la flèche engendre un courant secondaire sortant par la borne M.

- Protections :**
- Du circuit de mesure contre les court-circuits
 - Du circuit de mesure contre l'ouverture
 - De l'alimentation contre les inversions de polarité

Instructions de montage et d'utilisation suivant notre catalogue

CHARACTERISTICS

CARACTERISTIQUES

Nominal primary current (I_{PN})	<i>Courant primaire nominal (I_{PN})</i>	A r.m.s. (A_{eff})	: 2000
Measuring range (I_P max)	<i>Plage de mesure (I_P max)</i>	A peak ($A_{crête}$)	: ± 3000
Max. measuring resistance (R_M max)	<i>Résistance de mesure max. (R_M max)</i>	Ω	: 5 (@ $I_{Pmax} / \pm 24V (\pm 5\%)$)
Min. measuring resistance (R_M min)	<i>Résistance de mesure min. (R_M min)</i>	Ω	: 0 (@ $I_{PN} / \pm 24V (\pm 5\%)$)
Not measurable overload	<i>Surcharge non mesurable</i>	A peak ($A_{crête}$)	: ≤ 20000 (10ms/h)
Turn ratio (N_P/N_S)	<i>Rapport de transformation (N_P/N_S)</i>		: 1/5000
Secondary current (I_S) at I_{PN}	<i>Courant secondaire (I_S) à I_{PN}</i>	mA	: 400
Accuracy at I_{PN}	<i>Précision à I_{PN}</i>	%	: $\leq \pm 0.5$ (@ +25°C)
Accuracy at I_{PN}	<i>Précision à I_{PN}</i>	%	: $\leq \pm 1$ (-40°C ... +85°C)
Offset current (I_{S0})	<i>Courant résiduel (I_{S0})</i>	mA	: $\leq \pm 0.25$ (@ +25°C)
Linearity	<i>Linéarité</i>	%	: ≤ 0.1
Thermal drift coefficient	<i>Coefficient de dérive thermique</i>	mA/°C	: ≤ 0.02
Delay time	<i>Temps de retard</i>	μS	: ≤ 1
di/dt correctly followed	<i>di/dt correctement suivi</i>	A/μs	: ≤ 100
Bandwidth	<i>Bande passante</i>	kHz	: 0 ... 100 (-1dB)
No-load consumption current (I_{A0}) (Consumption current = $I_{A0} + I_S$)	<i>Courant de consommation à vide (I_{A0}) (Courant de consommation = $I_{A0} + I_S$)</i>	mA	: ≤ 25
Voltage drop (e)	<i>Tension de déchet (e)</i>	V	: ≤ 1.5
Secondary resistance (R_S)	<i>Résistance secondaire (R_S)</i>	Ω	: ≤ 30 (@ +85°C)
Dielectric strength	<i>Rigidité diélectrique</i>		
Primary / (Secondary + screen)	<i>Primaire / (Secondaire + écran)</i>	kV r.m.s. (kV_{eff})	: 12 (50Hz, 1min)
Secondary / screen	<i>Secondaire / écran</i>	kV r.m.s. (kV_{eff})	: 1.5 (50Hz, 1min)
Partial discharges	<i>Décharges partielles</i>		
Extinction voltage	<i>Tension d'extinction</i>	kV r.m.s. (kV_{eff})	: ≥ 2.3 (@ 10pC, 50Hz)
Supply voltage	<i>Tension d'alimentation</i>	V d.c.	: ± 15 ... ± 24 ($\pm 5\%$)
Mass	<i>Masse</i>	Kg	: 1.5
Operating temperature	<i>Température de service</i>	°C	: -40 ... +85
Storage and starting temperature (Unwarranted accuracy)	<i>Température de stockage et démarrage (Précision non garantie)</i>	°C	: -50 ... +90
Temperature of primary conductor in contact with the sensor	<i>Température du conducteur primaire en contact avec le capteur</i>	°C	: ≤ 100
Particularities	<i>Particularités</i>		
Burn-in test according to cycle	<i>Déverminage selon cycle</i>		: FPTC404304

The characteristics detailed in this leaflet are subject to change without prior notice

C_CS_8.doc

 AEROSPACE
& DEFENSE

 COACHES
& BUSES

RAILWAY



INDUSTRY



ENERGY

 PLEASURE
BOAT

 VERTICAL
TRANSPORT

 INDUSTRIAL
VEHICLES

 OFFSHORE
& MINING

PETERCEM.com

Noncontractual text & photographs